

Wedderburn®

Since 1896.



Semi-automatic Product
Strap Banding Machines

Model:RGW560II & RGW560IIS



RGW560II Adding value to your product with a sleek, flexible and tamper-resistant graphic banding label.

The RGW560II is a new concept in food presentation that showcases product while providing information and secure packaging.

Quick and easy to use, our DIGI Banding Machines can improve packing efficiency, food security and consumer appeal. They can also be programmed to enable compliance with Australian food labelling regulations.

If you require a weigh labelling option, the RGW560IIS model includes a trade approved DIGI Scale with 15 kg weighing capacity.

Eye-Catching Product Presentation

▲ Showcase product while providing information

The banding label's sophisticated graphic design printing allows customers a better view of the product and may increase their confidence in product selection and you can position the banding to maximise impact and security.

Other labelling techniques may limit the view of product and therefore reduce product appeal.

Banding is available in white, silver and clear for even greater control on how much of your product is seen.



Secure, Tamper-Resistant Packaging

▲ No manual taping required

The banding label uses a built-in heat seal to safely secure the package which; reduces chance of lids opening unexpectedly, deters and indicates deliberate tampering and eliminates the need to manually apply tape that may also compromise the visual appeal.



Additional POP / Barcode Labels

▲ Add extra appeal to printed bands

The built-in POP Labeller enables application of additional labels as part of the banding process.

Additional POP Labels are a convenient and efficient way to add your logo and colour for increased interest, brand awareness and instant appeal.



Specifications may change without notice

Product Strap Banding Machine

Model : RGW560II Series

Flexible Design Printing

▲ Print images, product data and advertising messages

The RGW560II enables flexible design for print on demand by thermal transfer method. The banding label provides considerable real estate to fit a wide variety of advertising messages or multiple lines of product information including; ingredients, storage instructions, "packed on and use by" dates and price. Weight information can be printed if using the scale model RGW560IIS.

Powered by DIGI 5600II intelligence means PLUs can be programmed to comply with relevant food labelling requirements including Plain English Allergen Labelling (PEAL).



High Performance Banding Material

▲ Packaging confidence and flexibility

Especially developed for DIGI RGW-560II Banding Machines, our BOPP film is heat-sealable on both sides and offers; very high seal strength, excellent water vapour barrier, exceptional puncture and impact resistance even at low temperatures, and superior optical properties.

Available in clear, white and silver.



Powered By DIGI 5600II Console

▲ Exceptional connectivity and usability

The RGW560II uses the DIGI 5600II series console to enable communication with other backroom wrapping machines or printers. The easy and familiar operation will help improve efficiency.



Specifications may change without notice

Product Strap Banding Machine

Model: RGW560II Series

Features Overview

- flexible on-demand thermal transfer printing
- legal for trade-use scale (Model # RGW560IIS)
- banding labels use a heat seal to secure the package
- up to 12 packs per minute (speed varies depending on length of the band format)
- banding label has space to fit multiple lines of information, images, barcodes and advertising messages
- flexible product strap eliminates the need for distracting labels allowing for better package design
- 10.4" touch screen LCD display
- built-in POP label applicator is an efficient way to apply additional labels with images and colour. Also used for barcode labels when using clear banding material.
- DIGI 560II series console enables communication with other backroom wrapping machines or printers
- PLUs can be programmed to conform to food labelling requirements such as PEAL

OPTIONS

- Foot switch



SPECIFICATIONS

MODEL:	RGW560II (without Scale)	RGW560IIS (with Scale)
Package size (mm):		Width: 50 - 240 Depth: 80 or more Height: 10 - 150
Banding speed:		up to 12 packs per minute (speed varies depending on length of the band format)
Banding film type:		OPP
Printing method:		Thermal transfer
Print resolution:		300 dpi
Film width (mm):		60
Printing area (mm):		300 maximum. (Between 95 - 395 mm from top of binding label)
Additional POP / Barcode Label Size (mm):		Width: 33 - 53 Height: 20 - 40
Display:		TFT LCD colour (10.4 inches) touch panel
Operation:		Mechanical keys and touch panel
Memory:		18 GB
Power requirement:		Single phase 240 V
Banding Machine dimensions (mm):		630 (W) x 325 (D) x 788 (H)
Scale dimensions (mm):	N/A	342 (W) x 285 (D) x 85 (H)
Scale weighing capacity:	N/A	6 / 15 kg x 2 / 5 g (multi-interval)
Net weight:	Approx 41.4 kg	Approx 45.2 kg

Specifications may change without notice

Product Strap Banding Machine

Model: RGW560II Series

LINE DRAWINGS

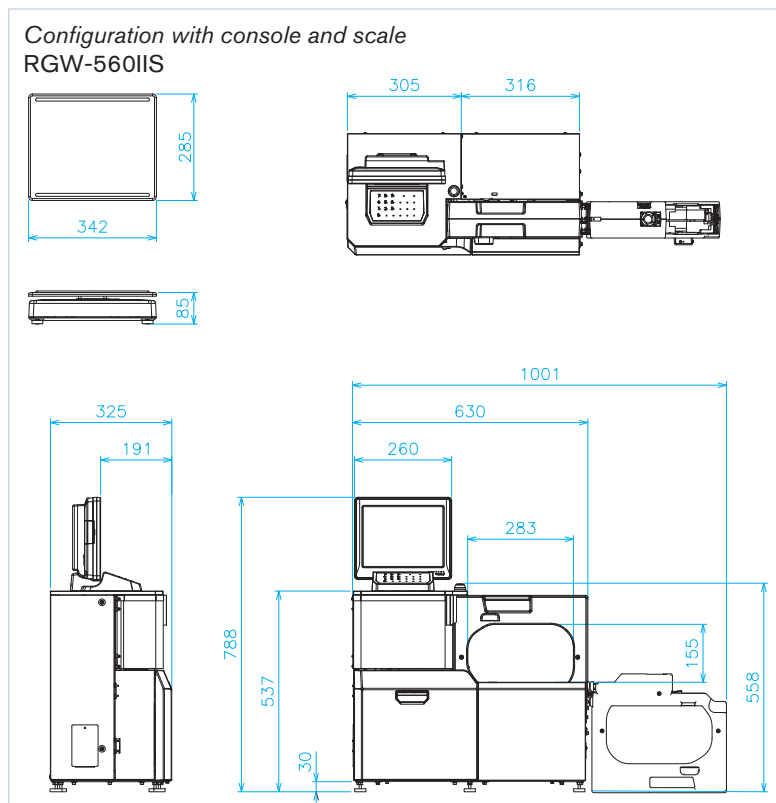
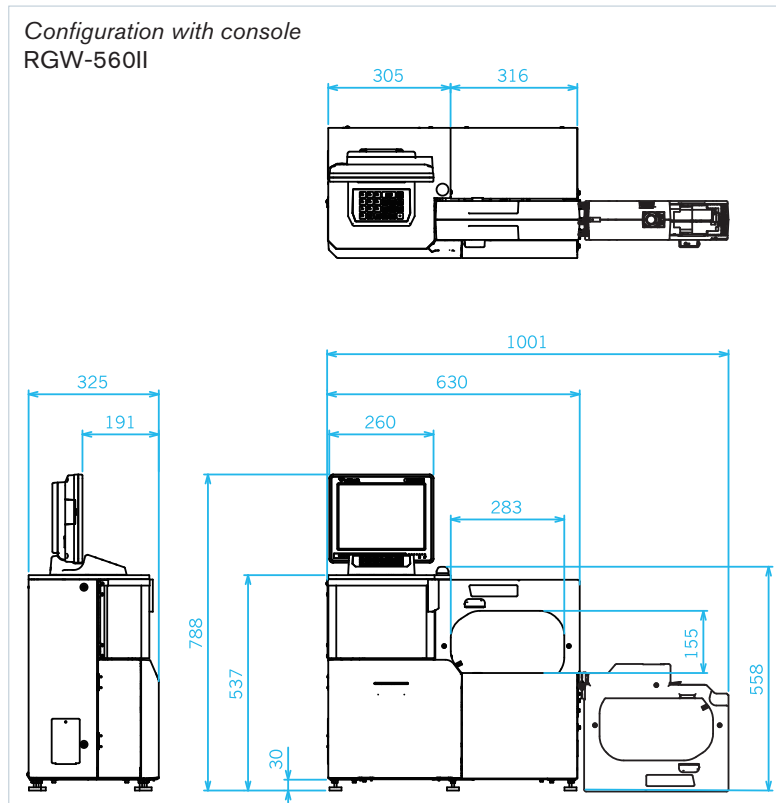

Specifications may change without notice