

# Semi-Auto Food Slicer

Model : WFS35SAGB3

Robust commercial grade, extremely quiet, semi-automatic food slicer with excellent features including a blade safety ring, salami holder and small footprint. The stroke length and speed of the carriage can be adjusted to suit the product being sliced according to its size and how delicate it is.

## FEATURES

WFS35SAGB3

- large 350mm blade diameter
- solid-state control panel impervious to water and resistant to harsh environments
- high capacity carriage for extra large cuts of meat
- integrated tilt-lifting device to enable easy cleaning beneath the carriage
- stow-away product holder for slicing flexibility
- patented Poly-V belt drive with automatic tensioner- NO belt slippage
- 3 carriage speeds and 3 stroke lengths allow efficient slicing of varying product sizes and how delicate it is
- 3rd generation blade, with low-friction cutting edge for precise low-force slicing
- salami holder: an additional adjustable "fence" to keep round products stable when slicing
- ample operator access for fast cleanup of food debris behind blade
- attractive highly polished aluminium alloy construction for easy cleaning and better hygiene

## SAFETY FEATURES

- blade safety ring: the blade is completely shrouded by a metal safety guard.
- safety interlock: the carriage interlock does not allow tilting of the carriage unless the index knob is set to zero. This prevents the blade from being exposed whilst cleaning and reduces the risk of injury.
- power fail safe: if mains power fails and is resumed, the slicer will not start until the slicer "on" button is re-selected by the operator. There is no risk of the slicer starting inadvertently.
- a large gap between the blade and motor housing allows easy access behind the blade for cleaning.
- CE Approved: this means the highest standards of design and manufacture have been adhered to for optimal user safety.

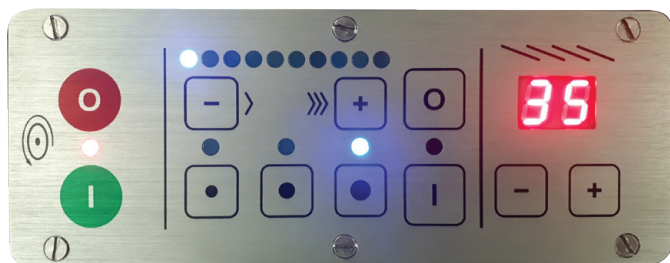

CLOSE UP OF OPERATOR PANEL



*Specifications may change without notice*

SPECIFICATIONS	WFS35SAGB3
Product Capacity (mm)	
Maximum diameter:	235
Maximum slice thickness:	25
Maximum length:	300
Maximum height:	160
Dimensions (mm)	
Blade Diameter:	350
Footprint:	450 (W) x 590 (D)
Working area required:	620 (W) x 800 (D) x 680 (H)
Motor:	IP65 rated water resistant
Weight:	48.0 kg

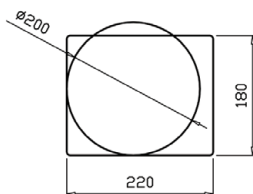
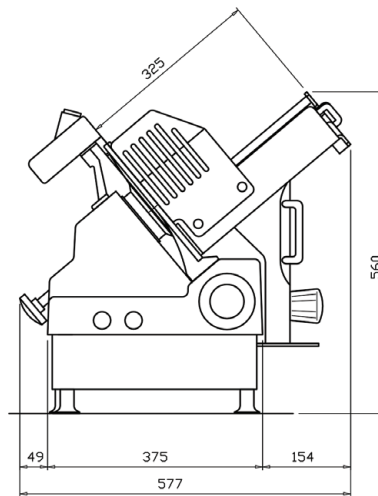
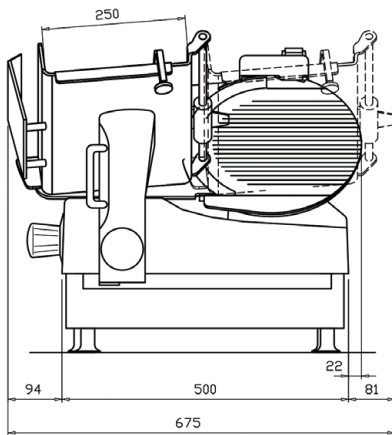

MAX. CUTTING SIZE:

 MAX. CUTTING SETTING: 15 mm

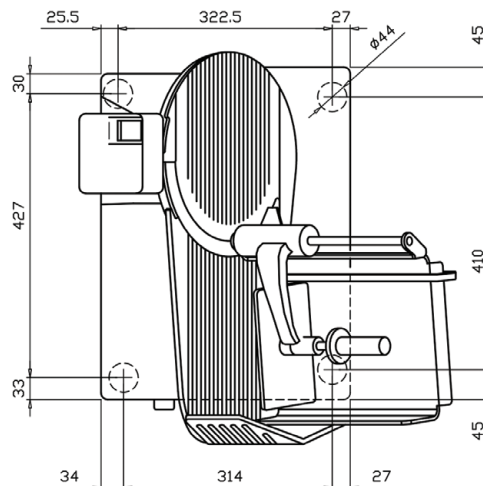

Specifications may change without notice