

# Customer Self-Service Scale

Model: SM6000SP15TLD

Enhance your customers' experience with this NMI approved weigh labelling scale. The large capacitive touch screen is portrait oriented for clear, simple and fast customer self-service when weighing, pricing and labelling goods. The SM6000 sets a new standard in Self-service Weigh Labelling and is the perfect solution for retailers seeking to improve store fitout aesthetics and delight their customers.

## FEATURES

## SM6000GSP15TLD

- legal for trade use
- 15" portrait, full colour touch screen display
- capacitive touch
- linerless Labelling
- virtual, on-screen level bubble
- auto-level compensation
- visual and audio operation guidance makes using this weigh, price, labelling scale a breeze
- front loading makes for easy label change
- high speed printing reduces wait time
- graphics printing on labels and receipts
- text or email alert can be set to notify the store or department manager that labels are running low
- remote diagnostics and support
- helpful on-screen operator prompts

## OPTIONS

- wireless comms interface
- electronic advertising info labels
- BYO container
- e.Sense - motion activated sensor to transmit PLU code automatically to scale



## VARIATIONS

Model Number	Max Capacity	Graduation	Platform Size (mm)	Overall Dimensions (mm)
SM6000GSP15TLD	15 kg	0 - 6 kg x 2 g 6 - 15 kg x 5 g	364 (W) x 284 (D)	364 (W) x 464 (D) x 762 (H)

*Specifications may change without notice*

**SPECIFICATIONS**

Legal for Trade Use	Yes
Scale Type	Bench
Display Panel - Operator	15" TFT XGA with Capacitive Touch
Label Printer Built-in	Yes
Label/Receipt Type	Linerless Labels
Label/Receipt Roll Diameter	95 mm maximum
Label/Receipt Paper Width	62 mm
Label/Receipt Print Resolution	300 dpi
Operating Temperature	- 10o C to + 40o C
Power	<input type="checkbox"/> Rechargeable Battery <input type="checkbox"/> Battery <input checked="" type="checkbox"/> Mains Power
Environment Suitability	<input checked="" type="checkbox"/> Dry <input type="checkbox"/> Wet <input type="checkbox"/> Harsh
Standard Interface	1 x Ethernet (RJ45), 4 x USB, 1 x RJ11

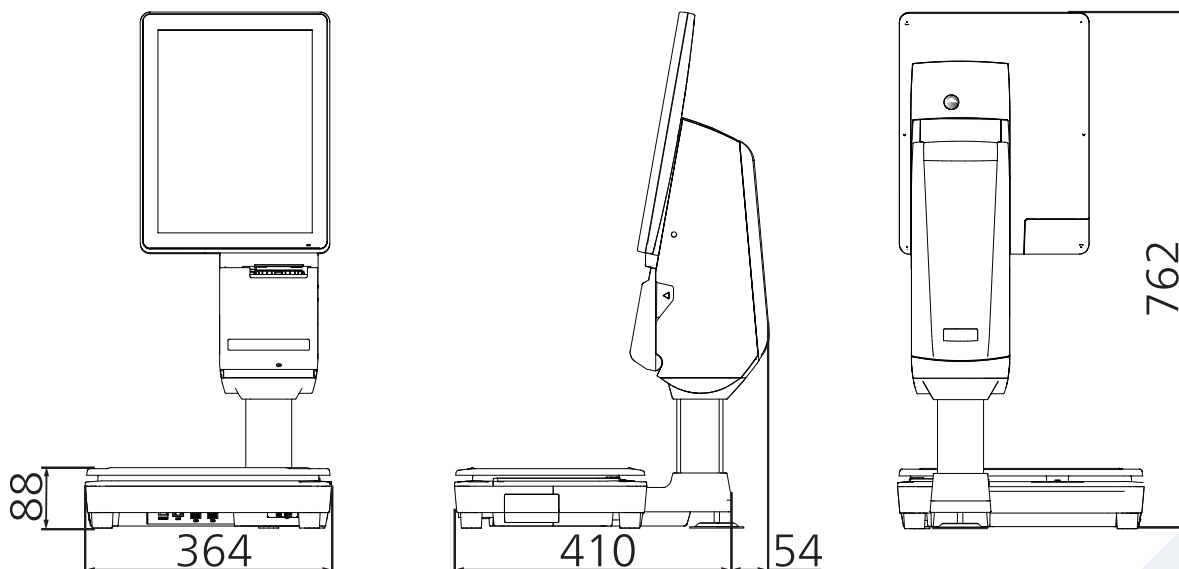

*Specifications may change without notice*