

Commercial Vacuum Sealer

Model: WFV93FGD27

Constructed from high-grade stainless steel and coupled with a premium quality vacuum pump, this ergonomic floor model, chamber vacuum sealer is designed for commercial use. It is simple to operate and can store up to 20 programmes and 10 soft vacuum programmes for liquids.

Our entire range of vacuum sealers have been designed and finished to the highest of standards in Italy. The superior build quality ensures it is one of the most reliable and trouble free machines available.

FEATURES

WFV93FGD27

- dual 520 mm sealing bars (front & back)
- high grade stainless steel construction
- easy to use digital LCD controls
- 20 programmes including soft vacuum for liquids
- 25 m³ per hour vacuum pump
- final vacuum 2.0 mbar
- piston welding bar for easy cleaning and longevity
- gas insertion point for regassing

SPECIFICATIONS

Sealing Bar Width (mm):	520
Overall Dimensions (mm):	650 (W) x 705 (D) x 1090 (H)
Power:	15 A single phase 0.75 kW, 230 V, 50 Hz
Weight of Unit:	approx 93 kg



Specifications may change without notice

DIMENSIONS:

Drawing Reference	Dimension Description	Size (mm)
A	Machine width (excluding fittings)	650
B	Machine depth including on/off switch	705
C	Machine height including feet & lid	1090
D	Inside chamber width	425
E	Inside chamber depth (inside front and back sealing bars)	530
F	Inside chamber height excluding domed lid	150
G	Inside height domed lid	80
H	Sealing bar width	520

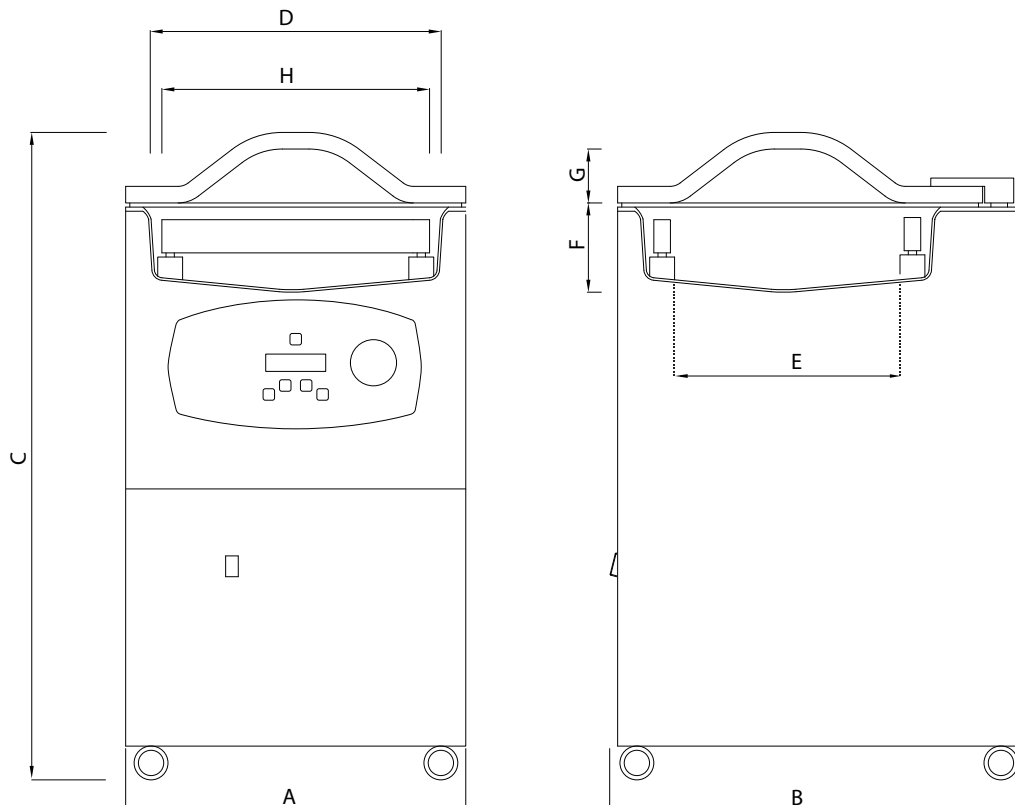

Specifications may change without notice