

# Bench Top Vacuum Sealer

Model: WFV36BGS27

Constructed from high-grade stainless steel and coupled with a high quality German Vacuum Pump, this bench-top chamber vacuum sealer is designed for commercial use.

It has a 320 mm sealing bar, is simple to operate and can store up to 20 programmes.

Our entire range of vacuum sealer machines has been designed and finished to the highest of standards in Italy. The superior build quality ensures it is one of the most reliable and trouble free machines available.

## FEATURES

WFV36BGS27

- front 320 mm sealing bar
- high grade stainless steel construction
- easy to use digital controls
- 20 programmes including soft vacuum for liquids
- 8 m<sup>3</sup> per hour vacuum pump
- piston welding bar for easy cleaning and longevity
- gas-flush function (MAP) to increase product shelf life and stability

## SPECIFICATIONS

Sealing Bar Width (mm): 320  
Overall Dimensions (mm): 420 (W) x 465 (D) x 420 (H)  
Power: single phase



*Specifications may change without notice*

**DIMENSIONS:**

| Drawing Reference | Dimension Description                     | Size (mm) |
|-------------------|---|-----------|
| A                 | Machine width (excl fittings)             | 420       |
| B                 | Machine depth including on/off switch     | 465       |
| C                 | Machine height including feet & lid       | 420       |
| D                 | Inside chamber width                      | 330       |
| E                 | Inside chamber depth                      | 280       |
| F                 | Inside chamber height excluding domed lid | 133       |
| G                 | Inside height domed lid                   | 70        |
| H                 | Sealing bar width                         | 320       |

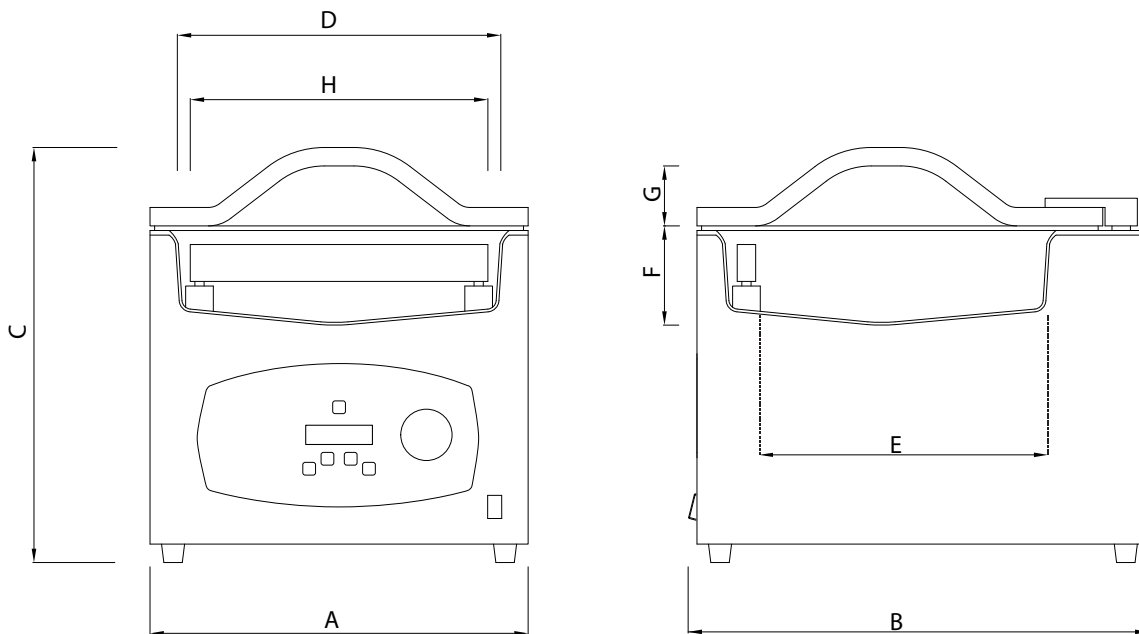

*Specifications may change without notice*