

# Bench Top Vacuum Sealer

Model: WFV25BAS27

Constructed from high-grade stainless steel and coupled with a premium quality Busch vacuum pump, this ergonomic bench-top chamber vacuum sealer is designed for commercial use.

It has a 260 mm sealing bar, is easy to operate and can store up to 20 programmes.

Our entire range of vacuum sealer machines has been designed and finished to the highest of standards in Italy. The superior build quality ensures it is one of the most reliable and trouble free machines available.

## FEATURES

WFV25BAS27

- front 260 mm sealing bar
- high grade stainless steel construction
- easy to use digital controls
- 20 programmes including soft vacuum for liquids
- 8 m<sup>3</sup> per hour vacuum pump
- piston welding bar for easy cleaning and longevity

## SPECIFICATIONS

Sealing Bar Width (mm):	260
Overall Dimensions (mm):	346 (W) x 480 (D) 390 (H)
Power:	single phase



*Specifications may change without notice*

**DIMENSIONS:**

Drawing Reference	Dimension Description	Size (mm)
A	Machine width (excluding fittings)	346
B	Machine depth including on/off switch	480
C	Machine height including feet & lid	390
D	Inside chamber width	270
E	Inside chamber depth	300
F	Inside chamber height excluding domed lid	120
G	Inside height domed lid	55
H	Sealing bar width	260

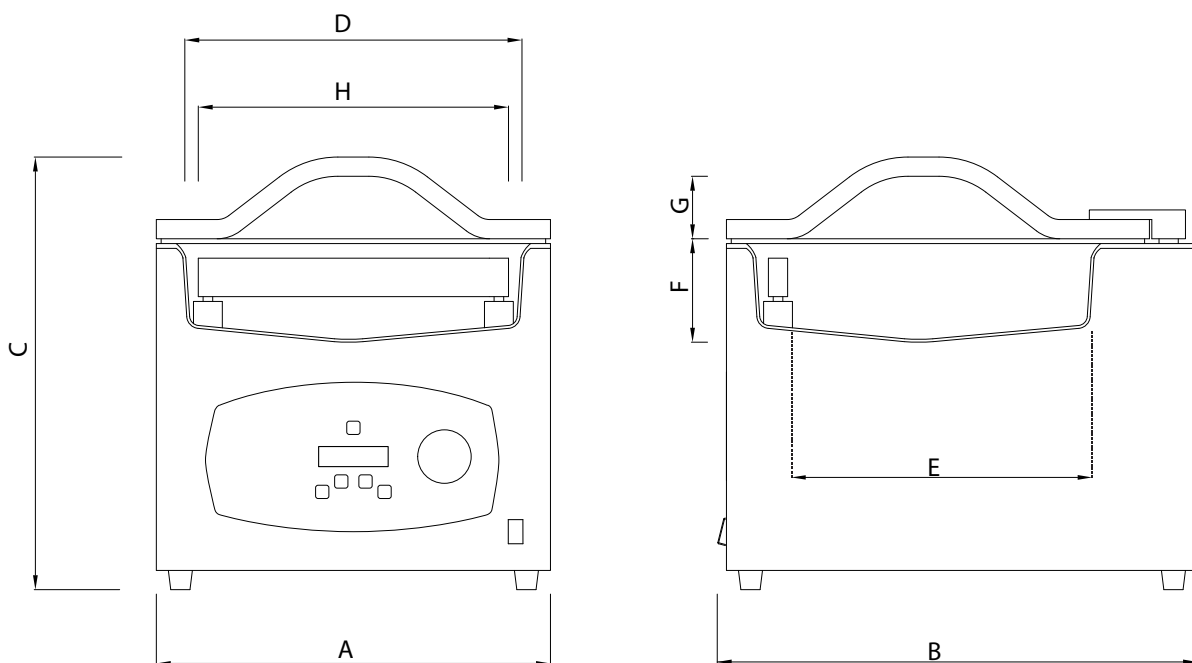

*Specifications may change without notice*