

Commercial Vacuum Sealer

Model: WFV175FGD27

Floor-standing vacuum sealer engineered for heavy commercial use. It features a high volume Becker vacuum pump, large capacity and gas-flush capability. It is simple to operate and can store up to 20 sealing programmes.

Our entire vacuum sealer range is designed and constructed in Italy to the very highest standards. You will be delighted with the superior finish and reliability of this vacuum sealer, which will give you years of trouble free use.

FEATURES

WFV175FGD27

- dual 750 mm sealing bars (front & back)
- high grade stainless steel construction including body work and chamber
- user friendly 20 programme digital control panel
- 71 m³ per hour Becker vacuum pump
- large capacity designed for heavy commercial use
- 63 m³ per hour oil-lubricated capacity
- final vacuum 2.0 mbar
- easy to read vacuum gauge
- heavy duty plastic spacer boards for increased efficiency and volume reduction when packing smaller products
- gas-flush function (MAP) to increase product shelf life and stability

SPECIFICATIONS

Sealing Bar Width (mm):	750
Overall Dimensions (mm):	870 (W) x 655 (D) x 1050 (H)
Power:	3 phase 415 VAC 50 Hz
Weight of Unit:	175 kg



Specifications may change without notice

DIMENSIONS:

Drawing Reference	Dimension Description	Size (mm)
A	Machine width (excluding fittings)	870
B	Machine depth including on/off switch	655
C	Machine height including feet & lid	1050
D	Inside chamber width	760
E	Inside chamber depth (inside front and back sealing bars)	540
F	Inside chamber height excluding domed lid	170
G	Inside height domed lid	80
H	Sealing bar width	750

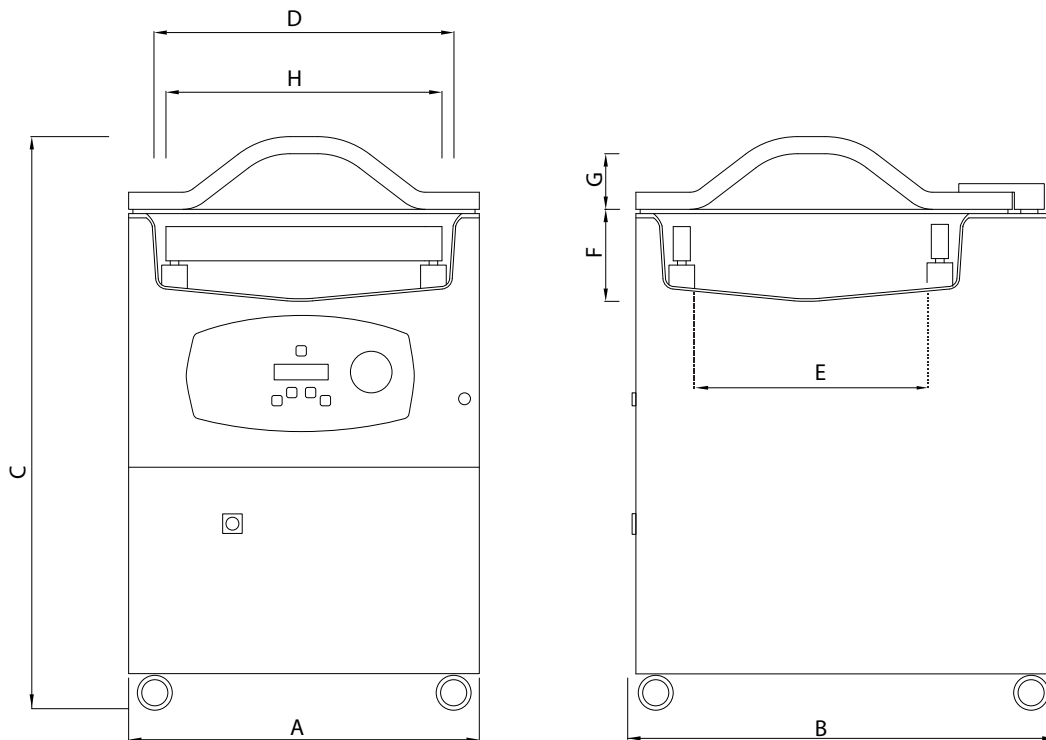

Specifications may change without notice