

## Bench Top Patty Maker

Model : WFP2013UV

The compact yet powerful Wedderburn bench-top patty maker is designed to form between 800 and 3700 patties per hour. Expect a fast return on investment as you easily add value to your product with this affordable machine.

As with all Wedderburn products, the patty maker is designed with safety in mind, with built-in safety interlocks that prevent the user from sustaining injury.

### FEATURES

WFP2013UV

- forms between 800 and 3700 patties per hour (variable speed)
- 20 litre hopper capacity
- precise portion control
- in-drum adjustment to easily adjust patty thickness/weight without the need for tools
- variety of standard shapes available including round, oval, square or sticks
- click-in/click-out drum interchange for easy exchange or cleaning of drums
- user selectable paper interleaving – great for non-stick stacking of patties, waxed paper is automatically placed under patties making patties easy to stack
- safe and efficient hands-free control of the machine via air-operated foot switch
- easy to disassemble for fast cleanup
- food contact parts are dishwasher safe

### OPTIONS

- Single Round – possible size range is between 56 mm and 130 mm in diameter
- Design your own patty shape – submit a design that fits inside a 100 mm diameter circle, and we will have a drum made for you.
- longer 900 mm conveyor belt
- larger paddles for product feeding
- 40 litre hopper available



Drums



Paper attachment



Easy-to-clean with removable parts



Operator panel



Specifications may change without notice

**SPECIFICATIONS**

Hopper capacity	20 litre (40 litre option)
Speed	800 to 3700 patties per hour (variable speed)
Conveyor belt (mm)	900 (option)
Dimensions (mm)	618 (W) x 637 (D) x 629 (H)
Electrical specification	230 V / 1-Phase / 50 Hz

**DIMENSIONS**

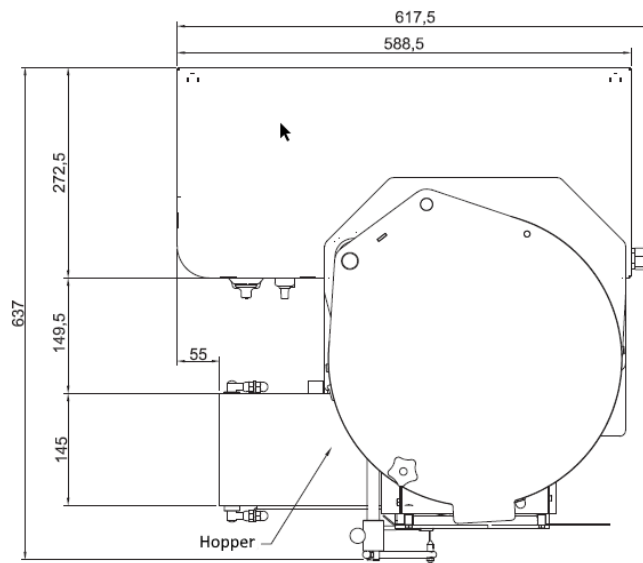

Top View

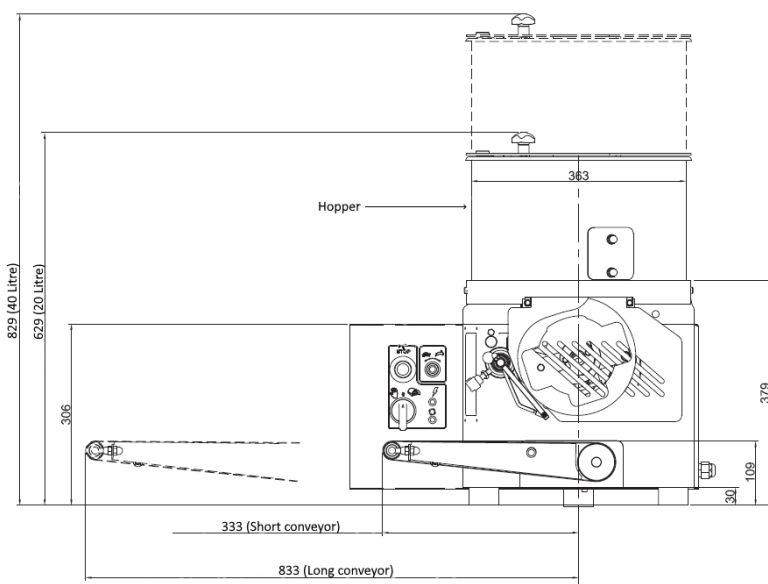

Front View

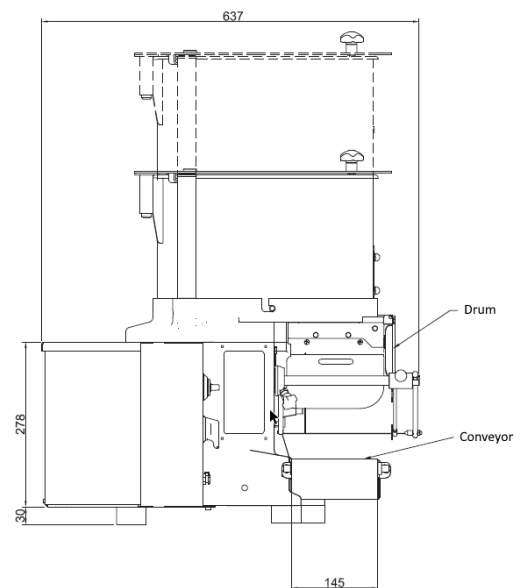

Side View

*Specifications may change without notice*