

Commercial Mixer Grinder

Model : DXTX98MINIMIX

This high performance mixer grinder is manufactured in France to the highest safety and manufacturing standards in Europe. The optional stand with four castors allows easy movement making it the perfect compromise between space and production output. The removable mixing paddle allows a thorough blend and easy cleaning upon completion of production.

FEATURES

DXTX98MINIMIX

- high performance compact mixer grinder
- CE certified to the highest safety and manufacturing standards
- safety isolation switches on lid and exit cover (optional feature only)
- entirely manufactured in stainless steel
- two motors with individual grease baths
- removable mixing arm for easy cleaning



Specifications may change without notice

SPECIFICATIONS	DXTX98MINIMIX
Power required:	415V, 50HZ, 10AMP three phase
Mincer motor:	2.2Kw
Mixing motor:	0.55Kw
Production:	600kg/h
Hopper capacity:	40L (approx 30kg)
Exit/plate size:	98mm Ø
Standard mincer system:	kidney, knife 5mm plate and spacer ring
Weight:	90kg

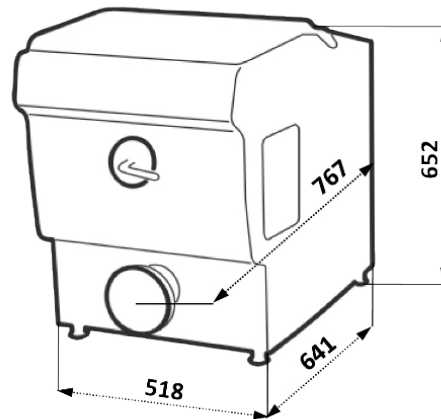
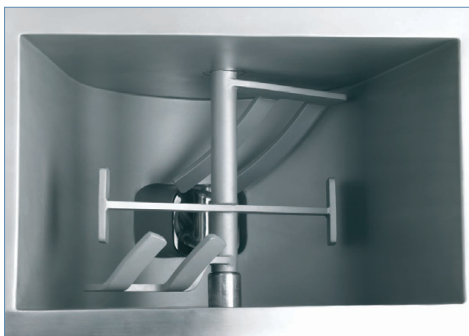

Specifications may change without notice