

Semi-Auto Food Slicer

Model : WFS30SAGB3

Heavy duty food slicer for consistent, quality slicing in harsh environments. These Food Slicers are engineered for heavy work loads.

FEATURES

WFS30SAGB3

- heavy duty with a compact footprint
- rubber protected switches that are resistant to water and to harsh environments
- stow-away product holder for slicing flexibility
- patented poly-V belt with auto-belt tension to prevent any slipping
- single speed and stroke length for consistency
- adjustable salami fence, keeping round products stable
- large clearance for easy cleaning
- mirror polished aluminum alloy for hygiene and ease of cleaning
- 10 AMP single phase power

SAFETY FEATURES

- blade safety ring; the blade is completely shrouded by metal
- safety interlock; carriage doesn't allow tilting unless index knob is set at zero
- power fail safe; prevents inadvertent starting after power cuts
- no blade removal required for cleaning
- CE approved. The highest global standards of design and manufacture have been met for optimum safety



SPECIFICATIONS

Model Number	Blade Diameter (mm)	Slice Thickness (mm)	Overall Dimensions (mm)
WFS30SAGB3	300	0-15	

Specifications may change without notice

SPECIFICATIONS	WFS30SAGB3
Product Capacity (mm)	
Maximum diameter:	200
Maximum slice thickness:	15
Maximum length:	220
Maximum height:	180
Dimensions (mm)	
Blade Diameter:	300
Footprint:	375 (W) x 500 (D)
Working area required:	577 (W) x 675 (D) x 560 (H)
Motor:	IP65 rated water resistant
Switches:	IP69 rated water resistant
Weight:	33.9 kg

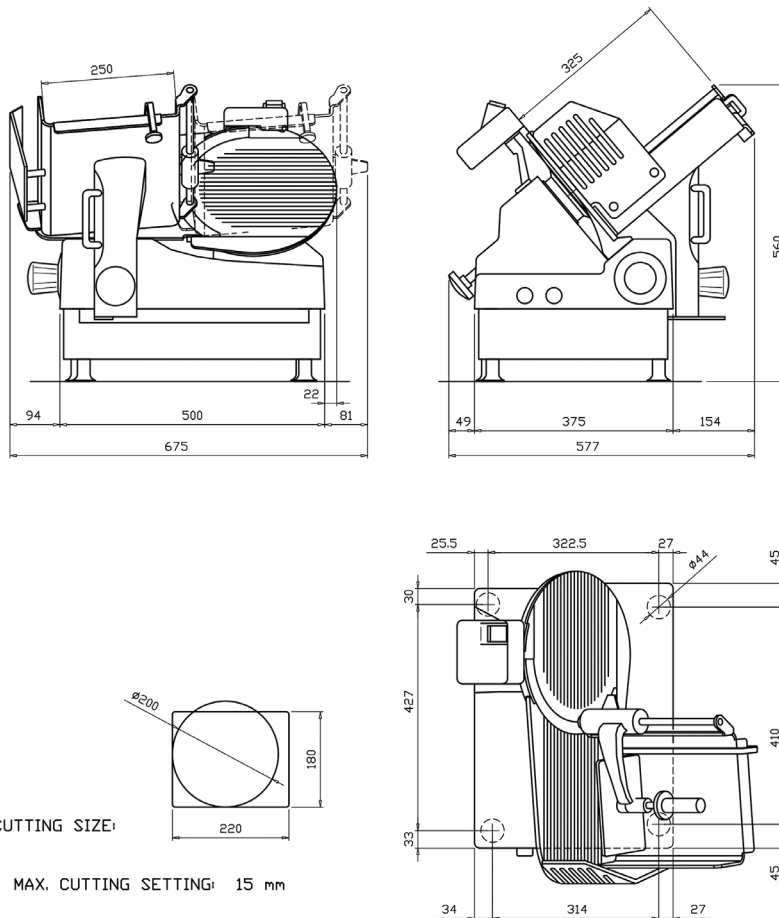

Specifications may change without notice