

Colour Touch Screen Weigh Labeller

Model : TSDPS5000E

Intelligent stand-alone colour touch screen labeller with stainless steel weighing platform and an option of a stainless steel printer stand. Trade approved in Australia.

FEATURES

TSDPS5000E

- legal for trade use
- direct thermal printing
- large stainless steel weighing platform
- easy label change with front loading label cassette
- built-in operator training modules
- touch screen operator display
- multimedia functionality
- remote diagnostics and support
- helpful on-screen operator prompts
- high resolution printing at 300dpi
- display panel rotates +/- 30° left / right and 0-90° up/down
- easily switch between receipt printing and label printing

OPTIONS

- wireless interface
- sturdy stainless steel printer stand (as shown)
- linerless with autocut



Specifications may change without notice

SPECIFICATIONS

Platform Capacity:	6/15kg x 2/5g or 15/30kg x 5/10g
Platform Size (mm):	355 (W) x 290 (D) x 58 (H)
Printer Dimensions:	220 (W) x 422.6 (D) x 407.5 (H)
Display:	NEC 8.4" TFT SVGA with Touch Panel with CCFL backlight
Printer Method:	Direct thermal printing
Paper Width:	Maximum 80mm
Label Size (mm):	30-80 (W) x 20-350 (H)
Print Head Resolution:	300dpi
Maximum Print Speed:	150 mm per second
Maximum Roll Diameter:	125 mm
Power Source:	AC Supply 200V / 240V
Power Consumption:	13W (min) 0.15A ~ 75W (max) 0.65A - (for AC 200V/240V)
Operating Temperature:	-10°C to +40°C
Humidity:	15% to 85% RH Non-Condensation
Standard Interface:	USB, Ethernet, 2xRS232 ports (mini DIN), SD socket
Printer Weight:	10.8kg
Net Weight:	16.36kg (printer and platform)
SD Card:	4GB (upgradeable)

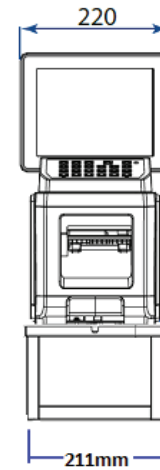
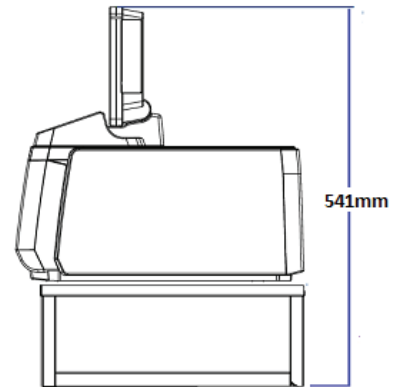

Shown with Optional
Bench Stand

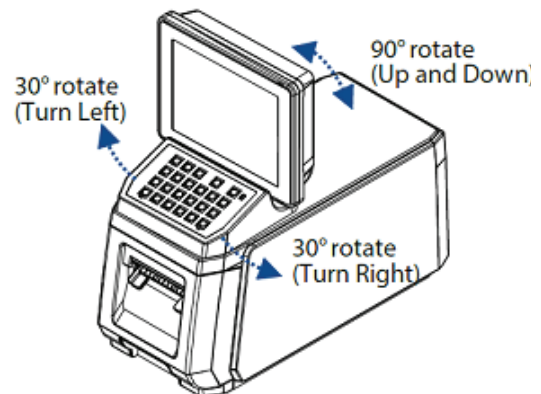
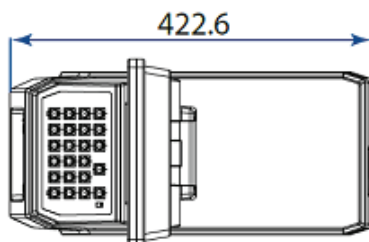
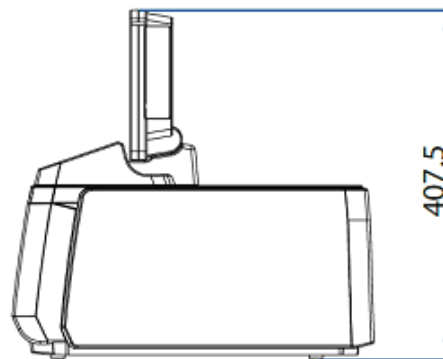
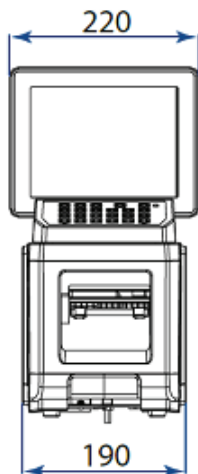

Specifications may change without notice