

Fully-Auto Food Slicer Stacker

Model : GFVA802

The Graef VA802 is a high quality, German Engineered, fully-automatic slicer. This gear driven slicer is simple to use thanks to the electronic interface and ergonomic controls. Up to 100 products may be programmed into the slicer, so your common settings can be retrieved from memory with the press of a button.

FEATURES

GFVA802

- fully programmable with 100 PLUs as standard
- blade: 300 mm diameter
- deposit types: stacking; longitudinal and transverse shingling; circular shingling
- slicer feed capacity: 230 mm
- slicing speed: 30 - 70 slices per minute
- slicing thickness: 0.5 - 10 mm (infinitely variable)
- Cera3, non-stick, abrasion resistant coated

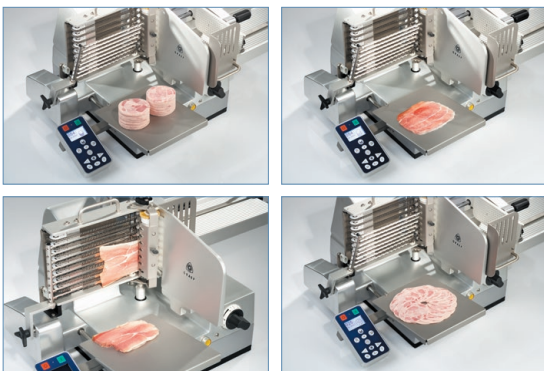

SPECIFICATIONS

Model Number	Blade Diameter (mm)	Slice Thickness (mm)	Overall Dimensions (mm)
GFVA802	300	0.5 - 10	880 (W) x 600 (D) x 500 (H)

Specifications may change without notice

ADDITIONAL SPECIFICATIONS

GFVA802

Product Capacities (mm)

Rectangular: 250 x 180

Round: 180 Ø

Dimensions (mm)

Blade Diameter: 300

Overall Dimensions: 880 (W) x 600 (D) x 500 (H)

Working area required: 900 (W) x 700 (D) x 640 (H)

Motor: 500 watts

Electrical specifications: 230 V / 1-Phase / 50 Hz

Net Weight: 69 kg

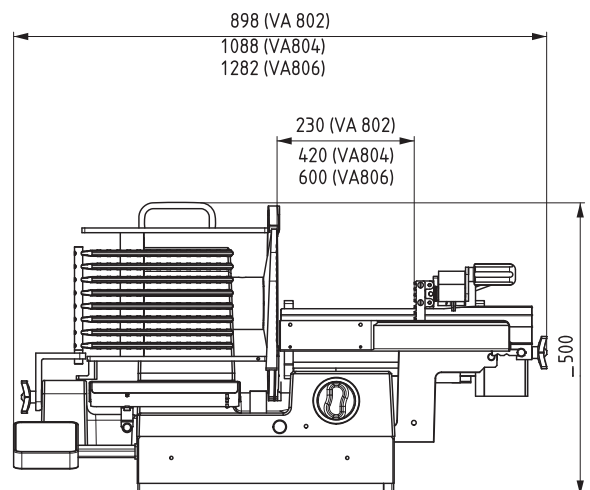
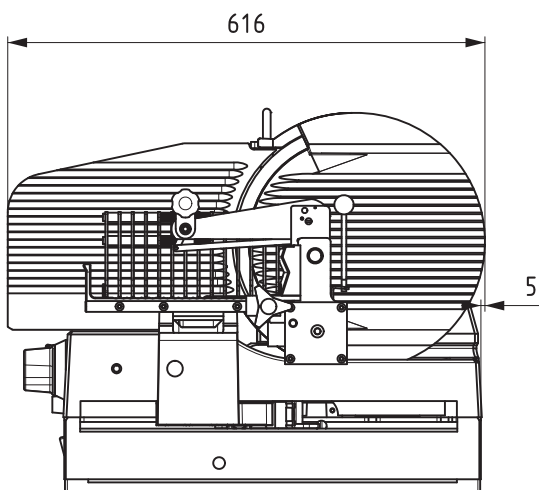
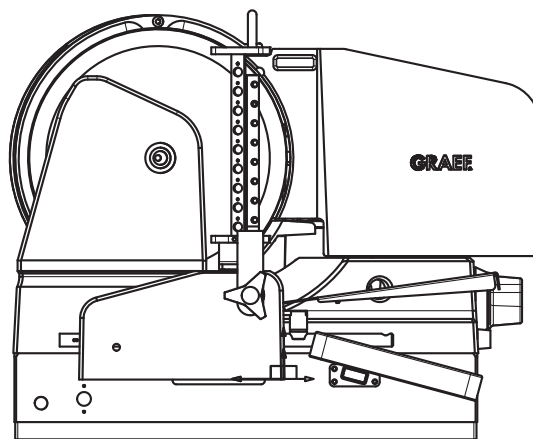

Specifications may change without notice